

PRODUCT #30S21 (Shown)
Pioneer Adaptor

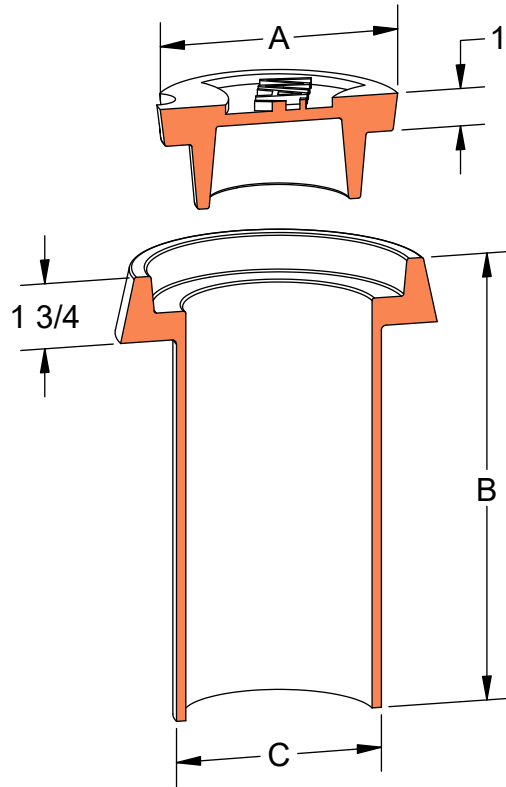

Product	A	B	C
30S10	5-5/8	6	4-1/2
30S11	5-5/8	12	4-1/2
30S20	6-3/8	6	5-1/4
30S21	6-3/8	12	5-1/4
30S22	6-3/8	18	5-1/4

Available Markings

- Gas
- Sewer
- Water

Notes

S10 and S11 are suitable for 4-1/4" Roadway Boxes.
S20, S21, S22 are suitable for 5-1/4" Valve Boxes.



Heavy
Duty



ASTM
A48



Gray Iron
Class 35B