

**PRODUCT #21231-WF**

12" x 12" Wide Flange Frame & Cover

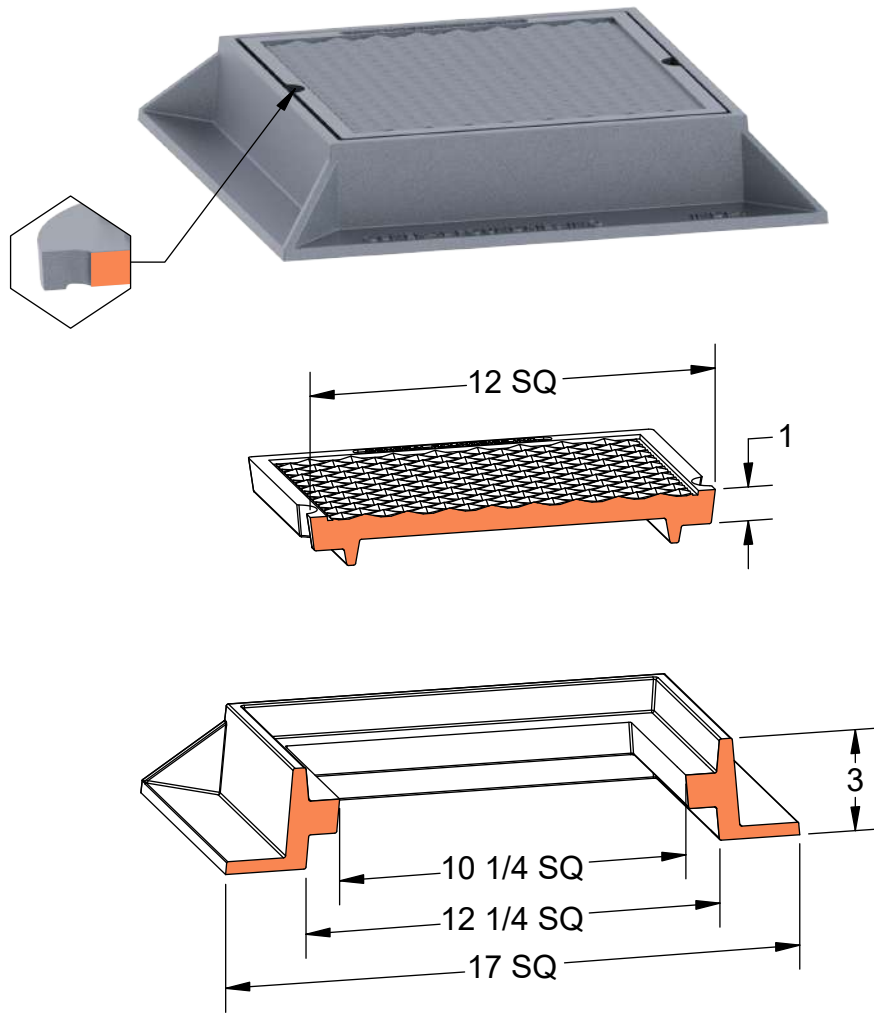

**Available Markings**

- Electric
- Plain
- Signal
- Traffic



Light Duty



ASTM A48



Gray Iron Class 35B



Reversible



Grates Available